

A44a BOARD-IN CRIMP TERMINAL WITH RESILIENT SOLDER TAIL FOR A44

PITCH: 1.5mm

SPECIFICATIONS

Material

Contact : Phosphor Bronze

► Wire Range : AWG#30 - 26

Insulation O.D. : 0.7 - 1.1mm

► Crimp Housing mating : A44 series.

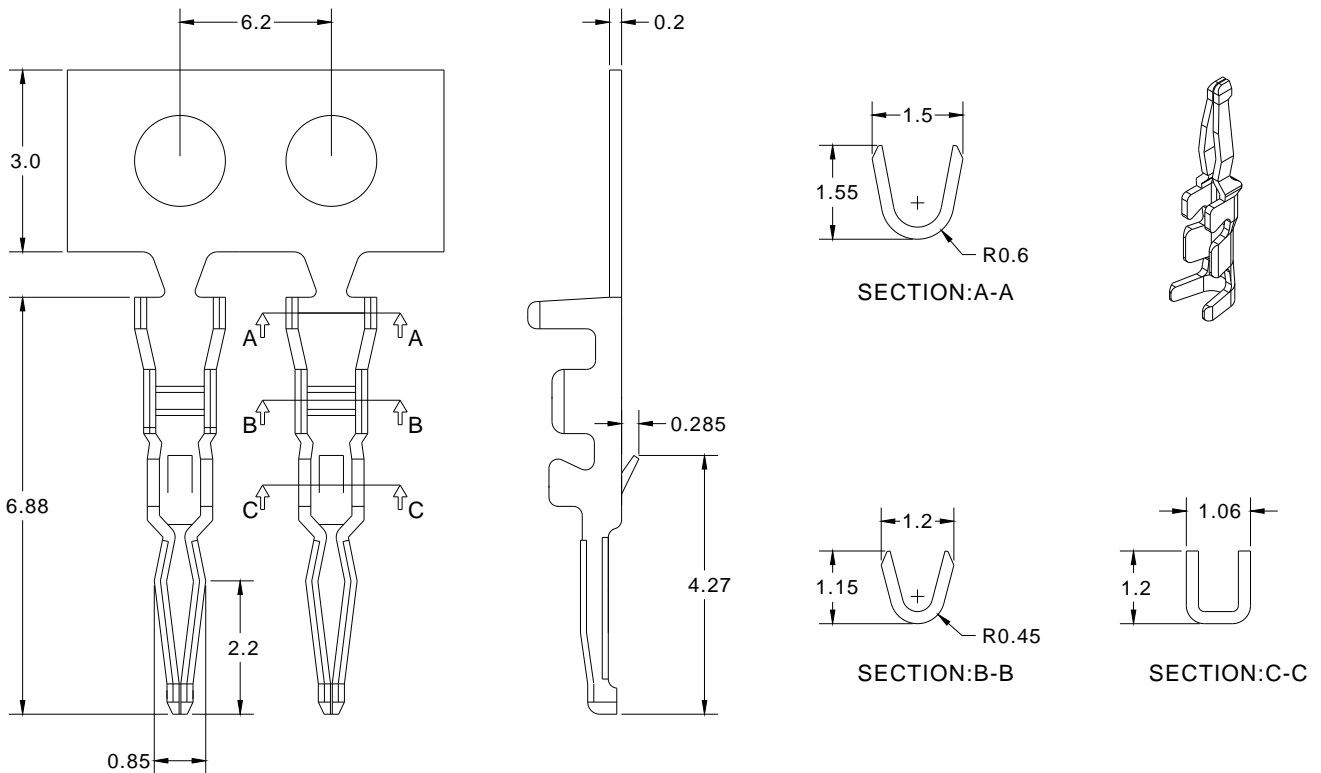
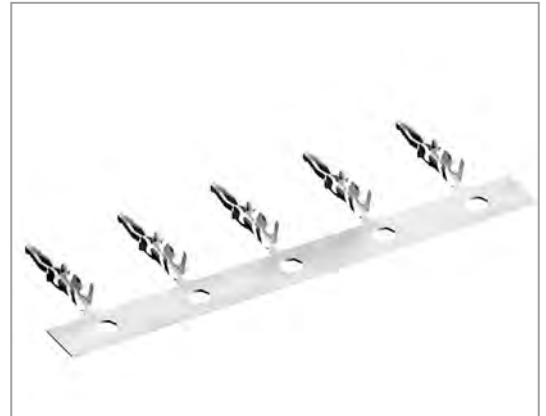

How to order: A44a - 1 - 2 - G(RoHS)

1.CONTACT MATERIAL	2.CONTACT PLATING
B: PHOSPHOR BRONZE	T: TIN PLATED