

C57b HALF PITCH MALE CONNECTORS WITH EJECTOR LATCH SMT STR

PITCH: 1.27mm * 1.27mm

SPECIFICATIONS

Material

Insulator: LCP, glass reinforced, rated UL 94V-0
Contact: Phosphor Bronze

Electrical

Current Rating : 1 Amp
Contact Resistance : 30 mΩ max.
Insulation Resistance : 1000 MΩ min.
Dielectric Withstanding Voltage : 250V AC for 1minute
Operating Temperature : -40°C to +105°C

► Mating Suggestion: A32d series.

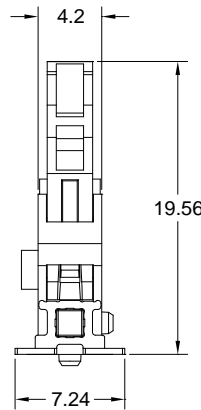
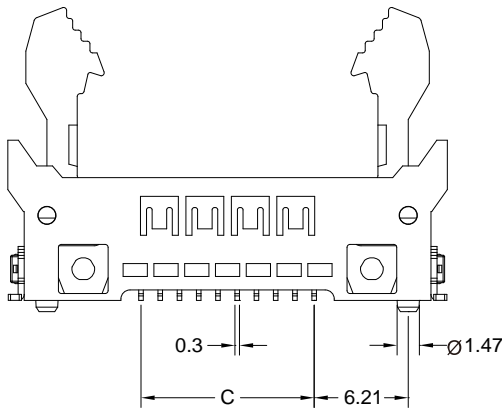
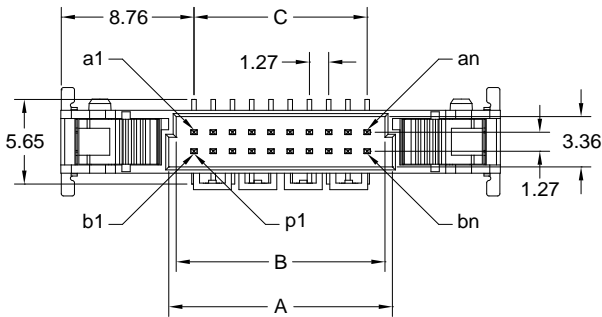
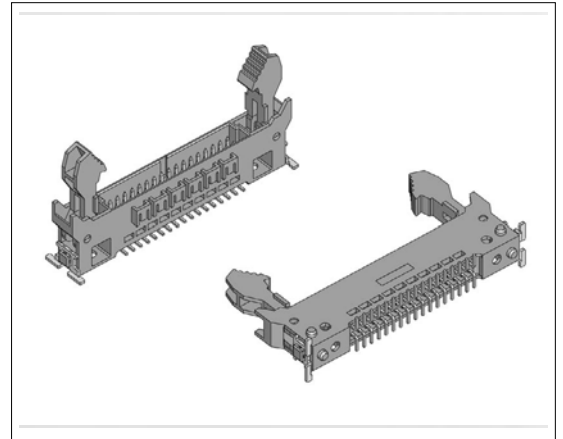

POSITION	A	B	C
6	5.87	4.89	2.54
8	7.14	6.16	3.81
10	8.41	7.43	5.08
12	9.68	8.70	6.35
14	10.95	9.97	7.62
16	12.22	11.24	8.89
20	14.76	13.78	11.43
22	16.03	15.05	12.70
26	18.57	17.59	15.24
30	21.11	20.13	17.78
34	23.65	22.67	20.32
40	27.46	26.48	24.13
44	30.00	29.02	26.67
50	33.81	32.83	30.48
60	40.16	39.18	36.83
68	45.24	44.26	41.91
80	52.86	51.88	49.53

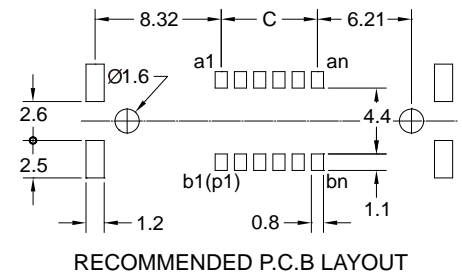

RECOMMENDED P.C.B LAYOUT

How to order: C57b - 1 - 2 - 3 - 4 - 5 - G(RoHS)

1.NO. OF CONTACT	2.CONTACT MATERIAL	3.CONTACT PLATING	4.PACKAGING	5.INSULATOR COLOR
06 08 10 12 14 16 20 22 26 30 34 40 44 50 60 68 80	B: PHOSPHOR BRONZE	T: TIN PLATED S: SELECTIVE G: GOLD FLASH A: 5u" INCH GOLD B: 10u" INCH GOLD C: 15u" INCH GOLD D: 30u" INCH GOLD	A: TUBE WITH PAD B: TUBE W/O PAD C: TAPE & REEL WITH PAD	1. BLACK



DON CONNEX
ELECTRONICS CO., LTD

T:886 2 86483356 | F:886 2 86485885
e-mail: info@donconnex.com.tw



Connector: E163339 | Flat cable: E162690
Wiring Harnesses: E312257

